

LIGHTING MULTI-CHANNEL BALLAST ICs

The IDC2000 ICs family devices are powerful digital SoC controllers for lighting control that integrate all the functions of high performance non-networkable and networkable single and multi-fixture electronic ballasts into one single chip. This controller comprises all of the control and protection functions required by the ballast and lamps as well as an embedded power line carrier modem. Additional optional communication interfaces provided by the IDC2000 ICs are: microLan, RS485, I2C, DC control, etc. for wired remote control and local remote control like RF (radio frequency) and IR (infrared). The IDC2000 ICs also provide interfaces for occupancy and lighting sensors, other digital and analog control I/Os. The configuration capability of this lighting controller for example, eliminates the need to tune a ballast circuit to different types of lamps by selection of passive components.



These ICs enable unique topologies allowing combination of different lamps within a fixture or within fixtures in a central ballast application and On or Off or smooth dim by remote control of individual lamps. The IDC2000 is also used in the master and local remote controls to complete the implementation of smart building control systems.

IDC2000 ICs - Major Advantages for Dimming Electronic Ballasts

- Low Cost / High Performance
- Shortest Time to Market
- Achieve Optimum Design in Days
- Code-free Configurability/Flexibility
- Remote Control Options: PLC, RF, DALI, etc.
- Common Hardware Platform
- Graphic User Interface Design Tools
- Drives any combination of lamp types
- Bridge power-switches dead-time protection
- Customizable Programmable Startup
- Individual Lamp Control/protection
- High Spec. Lamp Life Parameters
- Flexible Lamp Control
- Negligible flicker/high light quality
- Smooth Customized Dimming down to 0.1%
- Low THD throughout the entire dimming range
- Customizable Light Fade Rate
- Absolute Light level accuracy
- Enables the customization of a variety of different dimming techniques
- Multi-Channel/Multi-Fixture Ballast
- Supports Different Power Topologies
- Emergency Operation
- Energy Savings / Load Shedding
- Enables variety of PFC methods
- Interfaces to any sensor
- Allows Infringement-free Design

Device Models and Packaging Information

Device	Description	External Flash	Package	Legs/Pads
IDC2003E	Full Featured Engineering Device	✓	LQFP176	176
IDC2080	11 PSGs - 8 lighting channels		EPP LQFP	144
IDC2081	11 PSGs - 8 lighting channels	✓	EPP LQFP	144
IDC2040	5 PSGs – 4 lighting channels		QFN64 9x9	64
IDC2041	5 PSGs – 4 lighting channels	✓	QFN64 9x9	64
IDC2020	3 PSGs – 2 lighting channels		QFN64 9x9	60
IDC2021	3 PSGs – 2 lighting channels	✓	QFN64 9x9	60

IDC2000 General specifications

Function	Specification
IDC Outputs - Pulse Sequence Structure	Pulse Cycle Sequence (On-the-Fly Configurable)
IDC Outputs - Pulse Sequence Control	Responding to external and/or internal events
Pulse Modulation Methods	PWM, FM or any combination
# IDC Outputs	2080/1 22 (11 PWMs ¹)
	2040/1 10 (4 PWMs ¹)
	2020/1 5 (2 PWMs ¹)
# Analog Inputs	2080/1 23+PLC (11 with T&H)
	2040/1 11+PLC (8 with T&H)
	2020/1 11+ PLC (8 with T&H)
# Digital I/O	2080/1 52 (10 Schmidt-triggers)
	2040/1 10 (6 Schmidt-triggers)
	2020/1 10 (6 Schmidt-triggers)
A/D Converter	Pipeline 10 Bit
Sampling rate of single input	Up to 12MSPS sharing between inputs by configurable priorities
Analog input features	Comparator, Differential and Negative Amplifiers, Temperature sensor

Communication Interfaces	
Power Line Carrier	Two ways 2Kbit/Sec
	Complies with FCC and CENELEC
	10 ⁻¹⁰ BER (S/N 6dB)
RF Interface	2.4 MHz / 1Mbits
Serial Interface	2 x UART full duplex up to 1.5 Mbit/Sec
Parallel Port (IDC2003E)	up to 24bit (up to 48 MHz)

Function	Specification
Clock Frequency	192MHz
Output Pulse Resolution (without dithering)	5.3nS
Output Pulse Resolution (with dithering)	0.17nS
Pulse cycle composition	Each cycle composed of up to 16 different pulse widths
Minimum Pulse Width Minimum Control	26.5nS
PIDF Logic Engines for Close Loop Control Functions	2080/1 11
	2040/1 5
	2020/1 3
Calculation Time (PIDF)	170nSec
Min. total system response time to single input sample	900nS (additional 83nSec for each successive input sample)
Min. response time for external event	150nS
Total processing time of 24 inputs of IDC2080 or IDC2003E	2.9 uSec (pipeline processing)
System support & supervision	DR8052 high performance RISC CPU
Flash Memory	64 KByte
DPLL	Mains Zero Cross Digital Phase Locked Loop
Typical Applications	Control of multi channel/ multi phase DC-DC, DC-AC, AC-DC, AC-AC topologies
Control methods	- Multi (or single) voltage (or current) loop control - Average or Peak Current modes

Note 1 - Independent and complementary IDC Outputs
2 - IDC2003E has all the capabilities of the IDC2081 device



The PDK-L3.1 Lighting Design Tool allows configuration of the IDC2000 family to the desired ballast topology, control functions & performances.

More than 100 configurable parameters are available to tune the control functions to the targeted specifications. The PDK allows work to be carried out in a protected environment and tuning performance parameters on-the-fly.

The PDK is capable of supporting any envisioned ballast configuration, type of lamps and combination thereof. Design of single fixture or multi-fixture ballasts, dimmable or non-dimmable, with up to 8 different separate lamps or group of lamps is available with the PDK-L3.1.

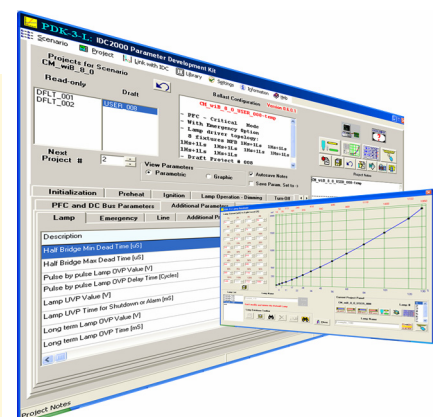

IDC2000 Electrical Characteristics

Parameter	Test Conditions	Min	Typ.	Max	Units
Crystal frequency	Preferred		12.00		MHz
Crystal frequency tolerance	Preferred		100.00		ppm
Analog and I/O VDD	Operation	3.135	3.300	3.630	V
	Start-up	2.924	3.030	3.136	V
	Shut-down	2.844	2.947	3.050	V
	Hysteresis	0.0800	0.0842	0.0860	V
VDD_Analog Current consump.			31		mADC
VDD_IO Current consumption			16		mADC
VDD_Core - Operation		1.710	1.800	1.980	V
VDD_Core - Start-Up		1.592	1.650	1.708	V
VDD_Core - Shut-down		1.551	1.607	1.663	V
VDD_Core - Hysteresis		0.0417	0.0432	0.0447	V
VDD_Core Current consumption	Start-Up VDD=1.8V - Under reset		1		mADC
	Sleep mode VDD=1.8V - "BIOS" period (48MHz, PLC operational, Control channels disabled)		45		mADC
	Steady state VDD=1.8V - 192M 11CH		250		mADC
	Steady state VDD=1.8V - 192M 6CH		195		mADC
	Steady state VDD=1.8V - 96M 11CH		129		mADC
	Steady state VDD=1.8V - 96M 6CH		99		mADC
VOH All Digital Outputs	VDD_IO=3.3V	2.40			V
VOL All Digital Outputs	VDD_IO=3.3V, IOL=-2mA			0.40	V
GPIO output min current*	VDD_IO=3.3V	4.00			mADC
PSG output min current	VDD_IO=3.3V	8.00			mADC
PWM output min current	VDD_IO=3.3V	8.00			mADC
VIH All I/O inputs	VDD_IO=3.3V	2.00		VDDIO+0.3	V
VIL All I/O inputs	VDD_IO=3.3V	-0.50		0.80	V
Cin ALL I/O inputs	VDD_IO=3.3V			0.80	pF
VIH GPI (Schmidt) inputs**	VDD_IO=3.3V	1.28	1.56	1.76	V
VIL GPI (Schmidt) inputs**	VDD_IO=3.3V	0.89	1.13	1.28	V
Hysteresis GPI inputs**	VDD_IO=3.3V	0.37	0.43	0.50	V
Cin ALL GPI inputs**	VDD_IO=3.3V		2.89		pF

IDC2000 Platform Architecture

The concept of this IDC2000 architecture allows the power expert, by relying on his skills alone, to develop and apply the most sophisticated control functions and/or the optimal topologies which are difficult to achieve with present solutions.

Code-free configuration of the IDC2000 using Systel's PDK Design Tool.

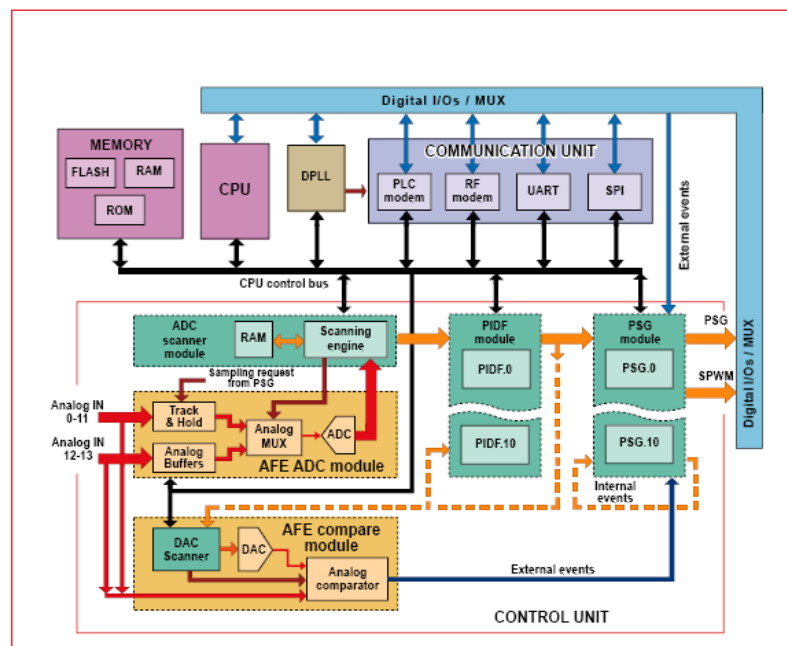

IDC2000 ICs Enable Ballasts Configurations as Below or Combinations

Ballasts based on Multi-Independent Half Bridges

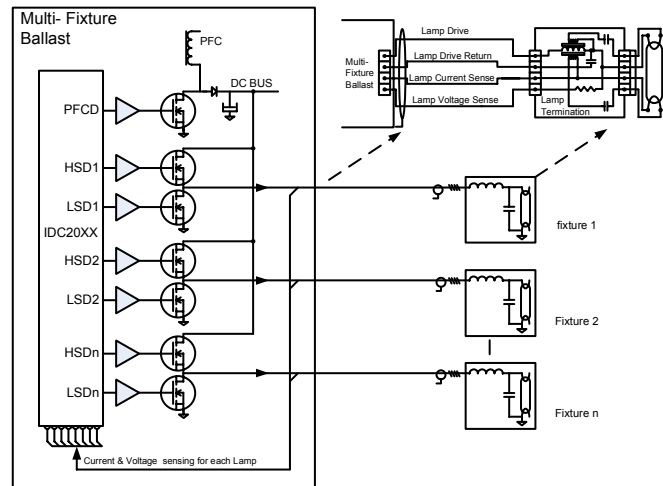
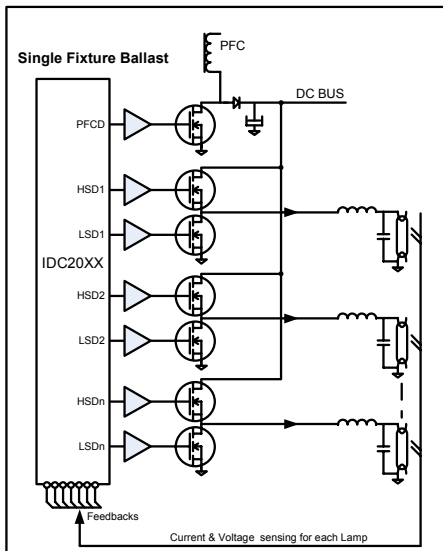

- Allows individual remote access to lamp/s or fixtures
- Allows individual drive and protection of each half-bridge and lamp/s
- Allows lamp/s connected to each channel to be separately dimmed to different levels, shutdown or switched on
- Allows connection of different lamp types and power to each channel

Ballasts based on Common High Side – Multi-Low Side Half-Bridges

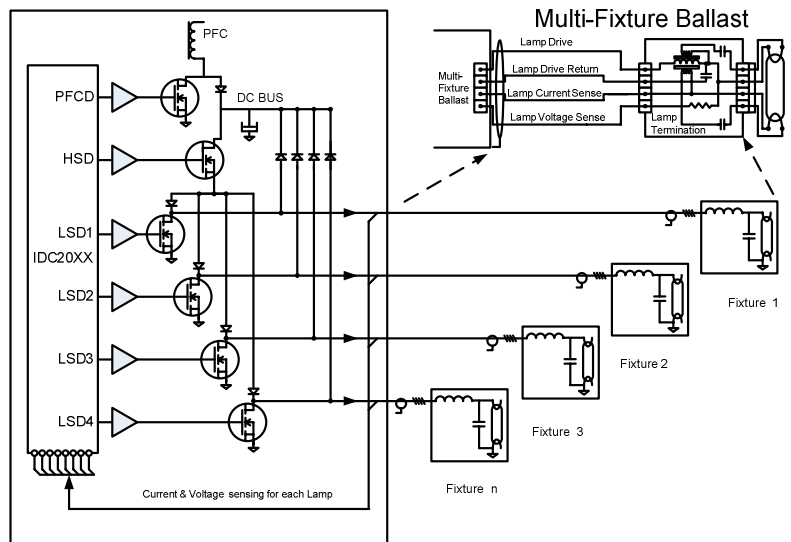
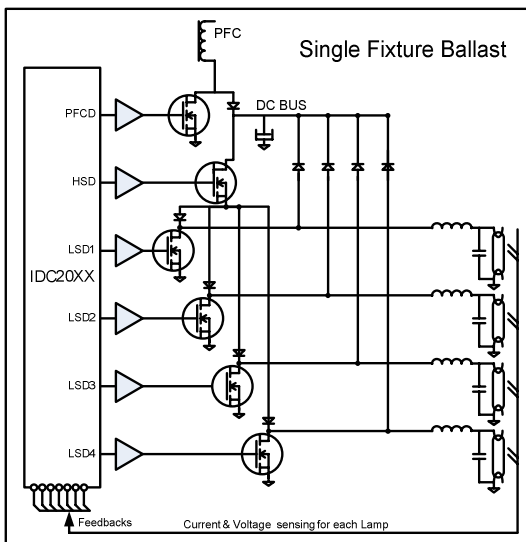

- Considering that all the lamps or fixtures are of the same power
- Allows uniform and equal dimming of all the lamp/s or fixtures
 - Allows separate protection of each half-bridge lamp/s
 - Allows individual remote control and monitoring of each lamp or fixture
 - Allows individual remote shut-down or switch-on of each lamp/s or fixture